



Segway™ Human Transporter (HT) Parking Stand Replacement Instructions

i Series models



Kit Contents

- > (1) Parking Stand Assembly
- > (2) 4 mm Hex Drive Parking Stand Fasteners
- > (6) T-20 Drive Fender Fasteners
- > (1) 16 mm Wheel Nut

Note: Replace any fasteners you remove with the new fasteners included in this kit.

Tools Required

- > 16 mm deep socket
- > Ratchet that will accept the 16mm deep socket
- > Torque Wrench set to 50 N-m that will accept the 16 mm deep socket
- > Rubber Mallet
- > Torx T-20 wrench/bit
- > Torx T-15 wrench/bit (if your Segway HT was purchased prior to March 2003)
- > 4 mm hex wrench/bit
- > Torque Wrench set to 1.5 N-m that will accept the Torx and Hex bits

Product Information

- > Nylon retractable stand
- > Foot activated lever
- > Spring action



Questions?

If you are missing a part, or if you need to return the product, please contact Segway Customer Operations at 1.866.4SEGWAY (1.866.473.4929) or on our website at www.segway.com/support/contact_us.html. Check www.segway.com for updates to this document. Thank you.



WARNING!

Always shut down your Segway HT and unplug the Power Cord before performing any maintenance or installing any part or accessory.

Follow these instructions carefully. Failure to follow these instructions could damage your Segway HT and render it unsafe to use.

LIMITED WARRANTY

The Segway HT Tire/Wheel Assembly Kit is a "Replacement Part" covered by the Segway™ Human Transporter Limited Warranty (copy delivered with the kit.)

> Removing the Tire/Wheel Assembly

- Step 1** Make sure the Parking Stand (i Series only) is retracted. Position the Segway HT Wheels on a non-slip surface. Brace the Wheel to be removed so it will not rotate when you loosen the Wheel Nut. You may find it easier to place the Handlebar on the ground.
- Step 2** Loosen the Wheel Nut with a 16 mm deep socket by turning the wrench counterclockwise. (This may require considerable force.) You may need to strike the end of the wrench with a rubber mallet. You can increase your leverage by extending the length of the wrench handle.
Note: Your torque wrench may be designed only for tightening. Check the manufacturer's specifications.
- Step 3** Tip the Segway HT onto its side with the Wheel you are removing facing up. Rest the other Wheel on a flat, clean, smooth surface (the p Series Wheel is dome-shaped, and is more vulnerable to scratches and rocking unless adequately supported and protected).
- Step 4** Remove the Wheel Nut.
- Step 5** Strike the outside edge of the Tire (not the Wheel!) with a rubber mallet to unseat the Wheel Hub Taper. (This may require multiple attempts as the Wheel Hub Taper is seated tightly into the Gearbox Taper.)
- Step 6** Lift off the Tire/Wheel Assembly.

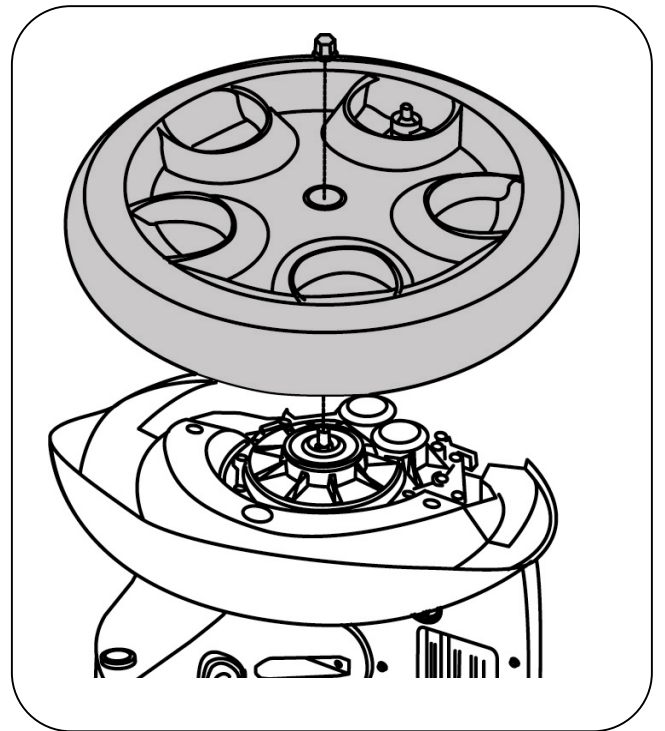
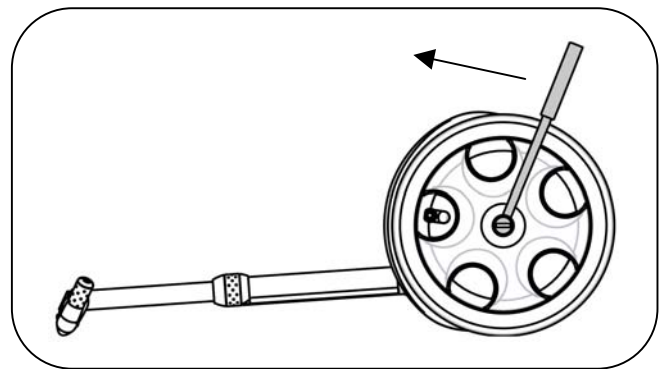

> Removing the Fender

- Step 1** Remove the six Fender fasteners using a T-20 six-lobed bit (Torx T-20) (T-15 Six Lobe bit if your Segway HT was purchased prior to March 2003). The plastic Fender is flexible. Twist the bottom right edge of the fender and flex it away from the Gearbox.
- Step 2** Disengage the mat loop from the Fender.
- Step 3** Remove the Fender.

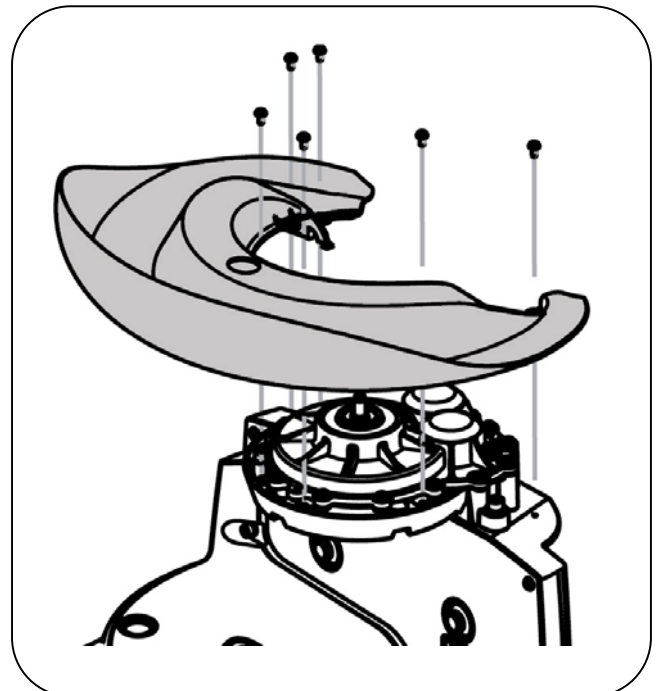

> Removing the Parking Stand

- Step 1** Remove the two 4 mm Hex Drive Parking Stand fasteners using the "L" shaped Hex Wrench included with your Segway HT.

Step 2 Disengage the Parking Stand lever from the Mat.

Step 3 Take a moment to review the position of the Parking Stand, as a point of reference for your installation.

Step 4 Remove the Parking Stand.

> Installing the Parking Stand

Step 1 Place the new Parking Stand Assembly against the side of the Platform, aligning the two fastener locations. The extrusion on the Parking Stand bracket will seat into the larger hole beneath the left fastener location.

Step 2 Thread in the two new 4 mm Hex fasteners. Torque to 0.5 N-m.

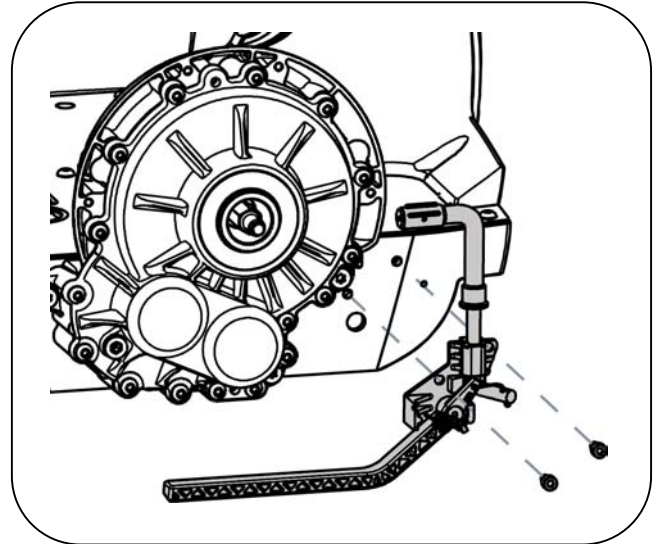

> Installing the Fender

Step 1 Position the bottom left edge of the Fender into place first. You will need to twist and flex the bottom right edge until it seats flat against the Gearbox. When seated properly, the six fastener locations will align with the fastener locations in the Chassis and Gearbox.

Step 2 Thread in and finger-tighten the six new Fender fasteners, beginning at the bottom edges of the Fender. Torque to 1.5 N-m using a T-20 six-lobed bit (Torx T-20). Over tightening could strip aluminum threads.

Step 3 (i Series and e Series models) Reach behind the Fender and reengage the mat loop into the Fender.

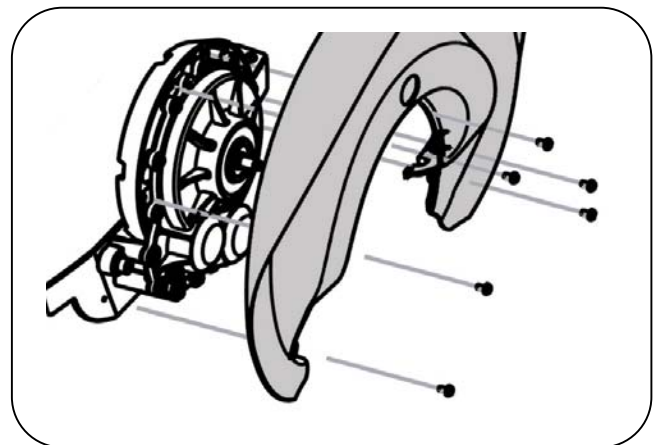

> Installing the Tire/Wheel Assembly

Step 1 Clean any debris from the outside of the Drive Shaft and the inside of the Wheel Hub Taper using isopropyl alcohol and a clean rag.

Step 2 Align the Tire/Wheel Assembly with the Wheel Hub Taper over the Drive Shaft. Rotate the Wheel while pressing down until the Wheel seats.

Step 3 Thread on the Wheel Nut. To reduce the risk of cross threading, use only the socket (without the wrench) to start the Wheel Nut.

Step 4 Position the Segway HT with the Wheels on a non-slip surface. Brace the Wheel so it will not rotate when you tighten the Wheel Nut; torque to 50 N-m.

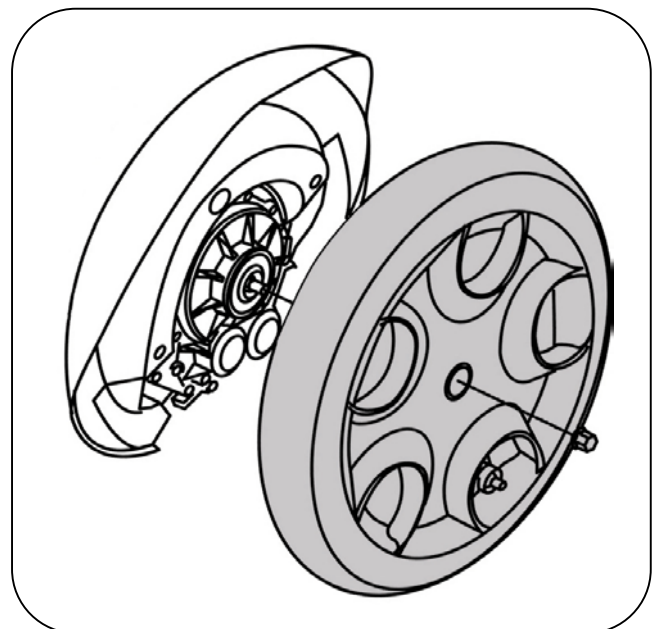

Check the tire inflation pressure. The air pressure stated on the Wheel label (near the inflation valve) supersedes any recommended pressure stated on the sidewall of the Tire.

We hope this procedure provided clear step-by-step instructions. If you feel these instructions are incorrect in any way, we would like to hear from you. Please contact Segway Customer Support at 1-866-4SEGWAY or go to www.segway.com if you have any questions, comments or suggestions. Thank you!